

**AMS-II.T.**

## Small-scale Methodology

---

# Emission reduction through reactive power compensation in power distribution network

Version 02.0

Sectoral scope(s): 02



**United Nations**  
Framework Convention on  
Climate Change

<b>TABLE OF CONTENTS</b>	<b>Page</b>
<b>1. INTRODUCTION .....</b>	<b>3</b>
<b>2. SCOPE, APPLICABILITY, AND ENTRY INTO FORCE .....</b>	<b>3</b>
2.1. Scope .....	3
2.2. Applicability .....	3
2.3. Entry into force .....	4
2.4. Applicability of sectoral scopes .....	4
<b>3. NORMATIVE REFERENCES .....</b>	<b>4</b>
<b>4. DEFINITIONS .....</b>	<b>5</b>
<b>5. BASELINE METHODOLOGY .....</b>	<b>5</b>
5.1. Project boundary .....	5
5.2. Identification of the baseline scenario .....	7
5.3. Additionality .....	7
5.4. Leakage .....	8
5.5. Emission reductions .....	8
5.5.1. Option 1: Determination of emission reductions using power flow simulation software: .....	8
5.5.2. Option 2: Determination of emission reductions by estimating loss reductions in the internal distribution system .....	9
5.6. Changes required for methodology implementation in 2 <sup>nd</sup> and 3 <sup>rd</sup> crediting periods .....	11
5.7. Data and parameters not monitored .....	11
<b>6. MONITORING METHODOLOGY .....</b>	<b>12</b>
<b>APPENDIX 1. GUIDANCE ON DETERMINATION OF TD LOSSES USING POWER FLOW SIMULATION SOFTWARE PACKAGES .....</b>	<b>16</b>
<b>APPENDIX 2. GUIDANCE ON USE OF SIMULATION SOFTWARE FOR DETERMINING TECHNICAL LOSS REDUCTIONS .....</b>	<b>18</b>
<b>APPENDIX 3. PROCEDURE TO ESTIMATE TRANSFORMER COPPER LOSS REDUCTIONS .....</b>	<b>26</b>

## 1. Introduction

1. The following table describes the key elements of the methodology:

**Table 1. Methodology key elements**

<b>Typical project(s)</b>	Installation of a reactive power compensation equipment at transformer substations
<b>Type of GHG emissions mitigation action</b>	Energy efficiency: GHG mitigation through energy savings in power distribution lines

## 2. Scope, applicability, and entry into force

### 2.1. Scope

2. This methodology covers project activities that improve power factor and reduce energy losses (kWh) in transmission/distribution lines through installation of either new or additional reactive power compensation facilities (RCF) such as at distribution transformer substations in industrial radial-power distribution network or at industrial internal distribution bus bars close to loads.

### 2.2. Applicability

3. The methodology is applicable under the following conditions:
- (a) Project activity consists of any or combination of the following:
    - (i) Installation of a new RCF in one or more transformer substations in industrial radial-power distribution network, or at industrial internal distribution bus bars close to loads where no RCF existed prior to the implementation of the project;
    - (ii) Installation of an additional RCF in one or more transformer substations in industrial radial-power distribution network or at industrial internal distribution bus bars close to loads, where RCF existed prior to the implementation of the project;
    - (iii) Retrofitting the existing RCF in one or more transformer substations in industrial radial-power distribution network or at industrial internal distribution bus bars close to loads.
  - (b) Reactive power compensation measures are carried out in facilities, which are connected to the grid;
  - (c) The RCF is a 'stand-alone' supply side energy efficiency intervention, not combined with the implementation of other demand side energy efficiency measures at the facility (e.g. replacing low power factor motor with efficient/ high

power factor motors), and the measure does not alter the load of the facility (e.g. capacity expansion of facility);<sup>1</sup>

(d) RCF design shall comply with national and international Power Quality standards for network operations;<sup>2</sup>

(e) The energy losses reduction that can be claimed are only those associated with the transmission / distribution lines and facility transformers where the reactive power flow is reduced due to RCF intervention. Please see the diagram under Project Boundary section.

4. The methodology is applicable in cases where baseline scenario is continuation of the current situation.

5. The methodology is not applicable in case there is any branching in between the distribution lines included in the project boundary, for which power losses reductions are calculated.<sup>3</sup>

### **2.3. Entry into force**

6. The date of entry into force is the date of the publication of the EB 102 meeting report on 28 March 2019.

### **2.4. Applicability of sectoral scopes**

7. For validation and verification of CDM projects and programme of activities by a designated operational entity (DOE) using this methodology, application of sectoral scope 02 is mandatory.

## **3. Normative references**

8. Project participants shall apply the “General guidelines for SSC CDM methodologies”, available at: <<http://cdm.unfccc.int/Reference/Guidclarif/index.html#meth>>.

9. This revision was based on request: “SSC\_737: Additional options to calculate emission reductions due to RPC intervention at demand side” submitted by the Competence Centre for Climate and Energy, of the GFA Consulting Group.

10. The initial methodology was based on the proposed new methodology “SSC-NM101: Greenhouse gas emission reduction methodology for reactive compensation in Power Distribution Network” prepared by:

(a) Shanghai Zhixin Carbon Asset Management Co., Ltd;

(b) State Grid Fujian Electric Power Research Institute;

(c) State Grid Fujian Electric Power Co., Ltd.

---

<sup>1</sup> Stakeholder may submit a request for revision of this methodology to cover such integrated measures.

<sup>2</sup> Example of international standards that deal with power quality requirements are IEC 61642, IEC 61000-2-2, IEC 61000-2-4, IEC 61000-2-12, EN 50160 (in Europe), IEEE 519 (USA) and national standard such as NRS 048 in South Africa.

<sup>3</sup> For example, there is no branching in the input lines as shown in the figures 1 and 2.

11. This methodology refers to the latest approved versions of the following tools:
- (a) "TOOL07: Tool to calculate the emission factor for an electricity system";
  - (b) "TOOL02: Combined tool to identify the baseline scenario and demonstrate additionality";
  - (c) "TOOL19: Demonstration of additionality of microscale project activities";
  - (d) "TOOL21: Demonstration of additionality of small-scale project activities".

## 4. Definitions

12. The definitions contained in the Glossary of CDM terms shall apply.
13. In addition, the following definitions apply:
- (a) **Facility transformer** - transformers normally installed at industrial facility (owned by the facility or Utility) to step-down the utility's distribution voltage level to facility's service voltage level (e.g., 88kV/11kV, 11kV/0.4kV etc.) and utility electricity meter is installed at high voltage /primary side of the transformer. Please refer to Figure 1, Appendix 3 for an illustration;
  - (b) **Industrial radial-power Distribution Network** - network that receives power from the national/regional grid at one location and allocates to various industrial users progressively (radial) by distribution facilities;
  - (c) **Project activity unit** - for this methodology the unit consists of one transformer substation and the output lines/feeders which are connected to it directly;
  - (d) **Reactive power compensation facilities (RCF)** - equipment that is installed at a project activity unit to improve the power factor and the quality of power supply.

## 5. Baseline methodology

### 5.1. Project boundary

14. The project boundary shall cover the following:
- (a) The input lines for which the emission reductions are calculated, are with the same voltage-level connected to the transformer substations and are included in the project activity unit boundary. The output lines of the transformer substations and the other remote transformer substations connected to input lines are excluded from the project activity unit boundary;
  - (b) The spatial extent of the electricity system(s) that the industrial facilities are connected to as defined in the "TOOL07: Tool to calculate the emission factor for an electricity system".

15. The project boundary is shown in Figure 1 and Figure 2 below.

**Figure 1. The project boundary of the one project activity unit under the baseline scenario**

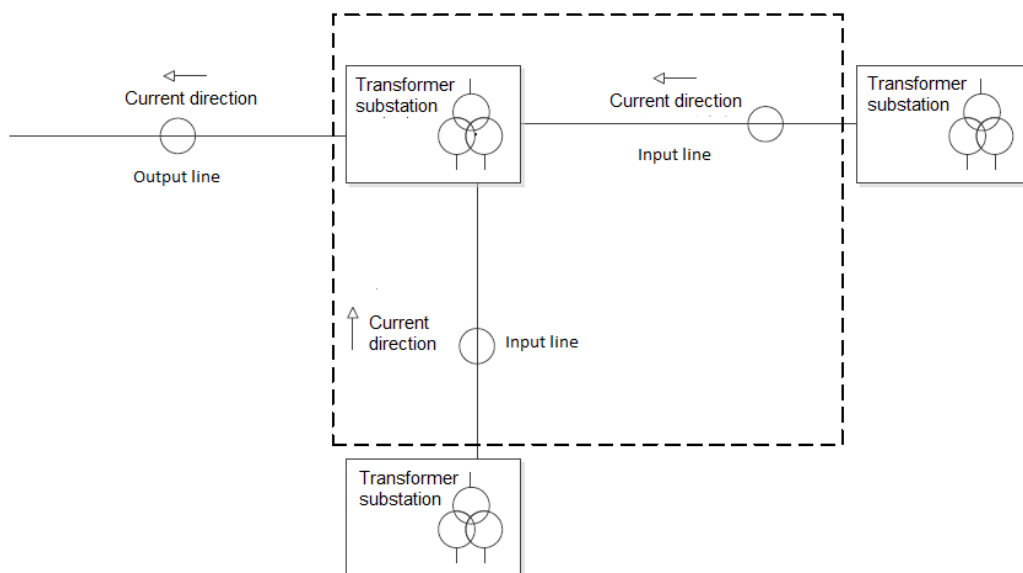

**Figure 2. The project boundary of the one project activity unit under the project scenario**

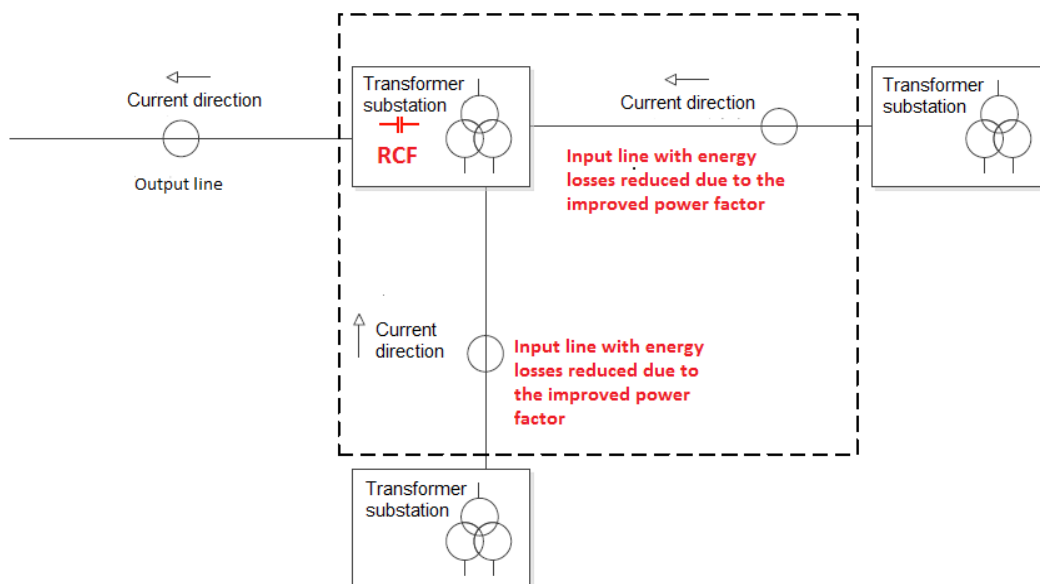

16. In the specific case of project activity where emission reductions are determined using power flow simulation model using transmission/distribution network parameters, the spatial extent of the project boundary encompasses:

- (a) The project transmission/distribution line from the point of origin/supply to the point of receipt including all the equipment (e.g. at substation) connected to it;

- (b) Substations/converter stations connected between the terminals are also a part of the project boundary;
- (c) The interconnected electricity grid to which the identified substations are connected is also included in the project boundary.
17. The greenhouse gases and emission sources included in or excluded from the project boundary are shown in Table 2.

**Table 2. Emission sources included in or excluded from the project boundary**

Source		Gas	Included	Justification/Explanation
Baseline	Transmission losses identified in the baseline scenario	CO <sub>2</sub>	Yes	Main emission source
		CH <sub>4</sub>	No	Minor emission source
		N <sub>2</sub> O	No	Minor emission source
Project activity	Transmission losses identified in the project scenario	CO <sub>2</sub>	Yes	Main emission source
		CH <sub>4</sub>	No	Minor emission source
		N <sub>2</sub> O	No	Minor emission source

## 5.2. Identification of the baseline scenario

18. The baseline scenario is identified as the most plausible baseline scenario among all realistic and credible alternative(s). At least the following baseline scenarios should be considered:
- (a) S1: Implementation of project activity without being registered as CDM;
- (b) S2: The continuation of the current situation. By default, the current situation shall represent the current regulation in the host country. For example, if the regulation requires the power factor to be equal or greater than 0.9, the current practice is to keep the power factor on the minimal required level (i.e. 0.9). However, if as a consequence of installed reactive power compensation technologies prior to project implementation, the power factor at industrial facilities is higher than that required by the regulation, the former shall represent the current situation. In cases where the current situation cannot be the baseline due to wide-spread non-compliance, adequate justification needs to be provided to use a value lower than the regulation;
- (c) S3: Implementation of the other technologies to improve the power factor, which are different from project reactive power compensation facilities.

## 5.3. Additionality

19. The investment barrier analysis shall be used to demonstrate additionality of the project activity using the latest approved version of the "TOOL21: Demonstration of additionality of small-scale project activities". The investment analysis shall take into account the avoided losses/penalties and the revenues from electricity savings due to the implementation of the project activity.

20. The project activity under the proposed methodology is not eligible to apply the provisions for automatic additionality specified under “TOOL21: Demonstration of additionality of small-scale project activities” and “TOOL19: Demonstration of additionality of microscale project activities”.

#### 5.4. Leakage

21. No leakage emissions are considered.

#### 5.5. Emission reductions

22. The emission reductions are calculated based on energy-savings in transmission/distribution (T&D) system due to project activity multiplied by emission factor of grid system. Energy savings are calculated using one of the following options (in preferential order):

- (a) Option 1 estimates energy savings by carrying out power-flow simulation of T&D network with and without project activity. This option shall be applied if the loads equal or exceed 7 MW and 5 MVA<sub>r</sub> per bus / node.
- (b) Option 2 calculates energy savings at the internal distribution system of the facility due to implementation of project activity. The corresponding electricity savings at the upstream T&D is done by taking into account information on T&D line losses (default value is included).

##### 5.5.1. Option 1: Determination of emission reductions using power flow simulation software:

23. This option requires the detailed representation of the transmission and/or the distribution system to carry out a power flow simulation. It considers the specific location of the RCF as well as site-specific parameters, such as resistance of the transmission and distribution lines supplying power to this specific facility.
24. Emission reduction shall be calculated as follows:

$$ER_y = \sum_{j=1}^{8760} (W_{loss,BL,j,y} + W_{Culoss,BL,y} - W_{loss,PJ,j,y} - W_{Culoss,PJ,y}) \times EF_{EL,grid,y} \quad \text{Equation (1)}$$

$EF_{EL,grid,y}$	=	CO <sub>2</sub> emission factor for grid connected project activity in year y (t CO <sub>2</sub> /MWh)
$W_{loss,BL,j,y}$	=	Total energy losses (transmission only, or distribution only or both) determining using load flow simulation in the baseline scenario in year y i.e. without RCF (MWh)
$W_{Culoss,BL,y}$	=	Transformer Copper losses in the baseline scenario in year y as determined following the procedure provided in Appendix 3 (MWh/yr)
$W_{loss,PJ,j,y}$	=	Total energy losses (transmission only, or distribution only or both) determining using load flow simulation i.e. with RCF (MWh)
$W_{Culoss,PJ,y}$	=	Transformer Copper losses in the project scenario in year y as determined following the procedure provided in Appendix 3 (MWh/yr)



25. Appendix 2 provides stepwise guidance on the determination of the energy savings due to reactive power correction using simulation.

### 5.5.2. Option 2: Determination of emission reductions by estimating loss reductions in the internal distribution system

26. Option 2 determines the reduction in energy losses (energy savings) including the losses occurring in the internal distribution system (i.e. the losses occurring after the point of utility electricity meter up to the RCF location). This option requires information on the number and length of the feeders in the internal distribution system as well as their resistance values ( $\Omega/\text{km}$ ).
27. Emission reductions shall be calculated as follows:

$$ER_y = \frac{(W_{BL,y} + W_{Culoss,BL,y}) - (W_{PJ,y} + W_{Culoss,PJ,y})}{(1 - TD_y)} \times EF_{EL,grid,y} \quad \text{Equation (2)}$$

With

$$W_{BL,y} = \sum_n \left( \frac{P_{p,n,H,y}}{U_{p,n,H,y}} \right)^2 \times R_{p,n} \times \frac{1}{\cos^2 \alpha_{H,n}} \times H_n \quad \text{Equation (3)}$$

and

$$W_{PJ,y} = \sum_n \left( \frac{P_{p,n,H,y}}{U_{p,n,H,y}} \right)^2 \times R_{p,n} \times \frac{1}{\cos^2 \beta_{H,n}} \times H_n \quad \text{Equation (4)}$$

Where:

$W_{BL,y}$	=	Line losses in the baseline scenario in year $y$ (MWh/yr)
$W_{PJ,y}$	=	Line losses in the project scenario in year $y$ (MWh/yr)
$TD_y$	=	Transmission and distribution losses or only transmission losses in case project activity is connected to the transmission network in year $y$ of the electricity grid supplying power to the industrial facility as determined using paragraph 28 below (dimensionless)
$P_{p,n,H,y}$	=	Active power delivered to the receiving end of the distribution network of the project activity unit $n$ in hour $H$ in the project scenario in year $y$ (kW)
$U_{p,n,H,y}$	=	Voltage of the project activity unit $n$ in hour $H$ in the project scenario in year $y$ (kV)
$R_{p,n}$	=	Resistance of the input lines of the project activity unit $n$ in the project scenario as determined following the paragraph 35 below ( $\Omega$ )
$\cos \alpha_{H,n}$	=	Power factor of project activity unit $n$ in hour $H$ in the baseline scenario
$H_n$	=	Operating hours of project activity unit $n$ in the project scenario (h)
$W_{P,y}$	=	Line losses in the project scenario in year $y$ (MWh/yr)
$\cos \beta_{H,n}$	=	Power factor of project activity unit $n$ in hour $H$ in the project scenario

28.  $TD_y$  shall be determined using the procedure below:
- (a) Use annual average technical TD losses determined based on the most recent, accurate and reliable data available for the country (e.g. data published either by a national utility or an official governmental body) also confirming exclusion of non-technical losses.
  - (b) If this is not available, following options may be used:
    - (i) Use Simulation-method following the guidance provided under Appendix 1;
    - (ii) Apply global default of 10%, where justification for the recentness/accuracy/reliability (including exclusion of non-technical losses) against using country-specific data could not be provided;
    - (iii) A default value of 3% for transmission losses shall be considered if project intervention is only connected to transmission network.
29. The reduction of copper losses of facility transformers due to project activity interventions should be determined following the procedure provided in Appendix 3. This component is however options and may be considered only under the following conditions.
- (a) The facility's metering point is located at the primary / high voltage (HV) side of the transformer and the RCF is located at secondary/low voltage (LV) side. This setup is illustrated by Figure 1 of Appendix 3. In such a setup, the loss reduction in the internal distribution system takes place from metering point up to the RCF node including transformer losses;<sup>4</sup>
  - (b) Transformer copper losses<sup>5</sup> are not included in the TD loss as estimated under paragraph 28 above;
  - (c) Evidence or a confirmation from the transmission distribution company is needed, that copper losses associated with facility transformer are excluded from the estimates of TD.
30. Resistance of input lines of the project activity unit in the project scenario shall be calculated as follows:

$$R_{P,n} = x \times R_{cond,n} \times L_{P,n} \quad \text{Equation (5)}$$

Where:

$x$  = Number of 3 phase lines/feeders (3 conductors, no neutral line considered) or one phase line/feeder of the project activity unit in the project scenario for which the losses reduction can be claimed

<sup>4</sup> The energy demand (kWh/KVAh) measured by the meter at the HV side also includes transformer and feeder losses.

<sup>5</sup> For example: i) copper losses are included in the TD loss estimate, if the estimate was produced using power flow simulation software and ii) copper losses are not included in the TD loss estimate, if the losses are produced by evaluating the difference between power generated / sent out and the electricity billed to customers.

$R_{cond,n}$  = Resistance per kilometre of the lines/feeders of the project activity unit n in the project scenario ( $\Omega/\text{km}$ )<sup>6</sup>

$L_{p,n}$  = Length of the lines/feeders of the project activity unit n in the project scenario (km)

## 5.6. Changes required for methodology implementation in 2<sup>nd</sup> and 3<sup>rd</sup> crediting periods

31. Refer to the tool “Assessment of the validity of the original/current baseline and to update of the baseline at the renewal of the crediting period”.

## 5.7. Data and parameters not monitored

32. In addition to the parameters listed here, the provisions on data and parameters not monitored in the tools referred to in this methodology apply.

**Data / Parameter table 1.**

<b>Data / Parameter:</b>	$x$
Data unit:	-
Description:	Number of phases (3 phases or 1 phase, no neutral line considered) of the project activity unit in the project scenario for which the losses reduction can be claimed
Source of data:	Project Feasibility Study Report submitted for its approval for example to government agencies or financial institutions
Measurement procedures (if any):	N/A
Any comment:	N/A

**Data / Parameter table 2.**

<b>Data / Parameter:</b>	$R_{cond,n}$
Data unit:	$\Omega/\text{km}$
Description:	Resistance per meter of the lines/feeders of the project activity unit n in the project scenario

<sup>6</sup> For example, if the line loss calculation involves 3 phase feeder, resistance of a conductor is 0.05  $\Omega/\text{km}$  and length of the each feeder is 2 km then  $R_{p,n} = 3 * 0.05 * 2 = 0.3 \Omega$ .

Source of data:	One of the following sources shall be used as source of data (in preferential order): (a) Measured according to IEC 60468 (Method of measurement of resistivity of metallic materials); (b) Test report issued by the third-party testing institutions; or (c) Product Specification provided by the manufacturer or calculated by relevant parameters; or (d) Project feasibility study report (FSR); or (e) Project documents submitted to the government authorities for applications for approval; or (f) Project documents submitted to financial institutions for appraisal
Measurement procedures (if any):	N/A
Any comment:	N/A

**Data / Parameter table 3.**

<b>Data / Parameter:</b>	$L_{p,n}$
Data unit:	km
Description:	Length of the lines/feeders of the project activity unit n in the project scenario
Source of data:	Project Feasibility Study Report submitted for its approval for example to government agencies or financial institutions
Measurement procedures (if any):	N/A
Any comment:	N/A

**Data / Parameter table 4.**

<b>Data / Parameter:</b>	$n$
Data unit:	N/A
Description:	The number of the project activity unit in the project scenario
Source of data:	N/A
Measurement procedures (if any):	N/A
Any comment:	N/A

## 6. Monitoring methodology

33. All data collected as part of monitoring should be archived electronically and be kept at least for two years after the end of the last crediting period. One hundred per cent of the data should be monitored if not indicated otherwise in the tables below.
34. The monitoring provisions in the tools referred to in this methodology apply.

**Data / Parameter table 5.**

<b>Data / Parameter:</b>	$P_{p,n,H,y}$
Data unit:	kW
Description:	Average active power delivered to the receiving end of the distribution network unit $n$ in $H$ hours in the project scenario in year $y$
Source of data:	Measured by the project participant
Measurement procedures (if any):	Power measurement instrument or measurement equipment integrated in reactive compensation facilities in accordance with applicable national or international standards
Monitoring frequency:	Continuously
QA/QC procedures:	Shall be calibrated periodically for accuracy as per national/regional standard
Any comment:	N/A

**Data / Parameter table 6.**

<b>Data / Parameter:</b>	$U_{p,n,H,y}$
Data unit:	kV
Description:	Average voltage of the project activity unit $n$ in $H$ hours in the project scenario in year $y$
Source of data:	Measured by the project participant
Measurement procedures (if any):	Power measurement instrument or measurement equipment integrated in reactive compensation facilities
Monitoring frequency:	Continuously
QA/QC procedures:	Measurement equipment shall be calibrated periodically for accuracy as per international/national/regional standard
Any comment:	N/A

**Data / Parameter table 7.**

<b>Data / Parameter:</b>	$EF_{EL\ grid,y}$
Data unit:	t CO <sub>2</sub> /MWh
Description:	Combined margin CO <sub>2</sub> emission factor for grid connected project activity in year $y$
Source of data:	The value of the combined margin CO <sub>2</sub> emission factor can be calculated by the project participant or derived from the DNA or the Standardized Baseline website < <a href="https://cdm.unfccc.int/methodologies/standard_base/2015/sb4.html">https://cdm.unfccc.int/methodologies/standard_base/2015/sb4.html</a> >
Measurement procedures (if any):	Calculated using the latest version of the "TOOL07: Tool to calculate the emission factor for an electricity system"
Monitoring frequency:	As per the "TOOL07: Tool to calculate the emission factor for an electricity system"
QA/QC procedures:	As per the "TOOL07: Tool to calculate the emission factor for an electricity system"
Any comment:	N/A

**Data / Parameter table 8.**

<b>Data / Parameter:</b>	$\cos \beta_{H,n}$
Data unit:	-
Description:	Power factor of project activity unit $n$ in hour $H$ in the project scenario
Source of data:	Measured by the project participant
Measurement procedures (if any):	Power Factor Meter or measurement equipment integrated in RCF equipment
Monitoring frequency:	Continuously
QA/QC procedures:	Shall be calibrated periodically for accuracy as per international/national/regional standard
Any comment:	N/A

**Data / Parameter table 9.**

<b>Data / parameter:</b>	$\cos \alpha_{H,n}$
Data unit:	N/A
Description:	Power factor of project activity unit $n$ in hour $H$ in the baseline scenario
Source of data:	<ol style="list-style-type: none"> <li>1. For project activity involving retrofitting/modification, i.e. project activity corresponding to para 3 (a) (ii) and (iii), baseline power factor shall be determined as a maximum value between:           <ol style="list-style-type: none"> <li>(a) The average of the full one-year historic data immediately prior to the implementation of the project;                If historical information is not available, the baseline power factor shall be determined through a measurement campaign covering the period sufficient to capture the normal operating conditions. The measurement campaign shall be carried out by the accredited third party before project implementation or may be carried out ex post only if the metering device continuously monitors the baseline power factor; and</li> <li>(b) The minimal target value required by the current regulations (e.g. value specified by electric utility). In case regulation does not exist (or wide spread non-compliance of the regulation is evidenced), baseline power factor shall be determined solely using the historic data or measurement campaign as mentioned above.</li> </ol> </li> <li>2. For project activity involving new installations, i.e. project activity corresponding to para 3 (a) (i), baseline power factor shall be the latest available minimal value required by the local regulation. The value shall be updated annually with the latest regulation, as available. In case where regulation is not available, baseline power factor shall be determined using the ex post monitoring, i.e. by monitoring the power factor demanded by the load in the baseline scenario</li> </ol>
Measurement procedures (if any):	Power Factor Meter or measurement equipment integrated in RCF equipment applicable to the cases where power factor is determined based on measurement)
Monitoring frequency:	N/A

AMS-II.T.

Small-scale Methodology: Emission reduction through reactive power compensation in power distribution network

Version 02.0

Sectoral scope(s): 02

---

QA/QC procedures:	RCF equipment shall be calibrated periodically for accuracy as per international/national/regional standard
Any comment:	Where baseline power factor is determined using ex-post measurement, it is possible that integrated RCF equipment monitors power factor supplied by the power utility and demanded by the electric motor at the same time and continuously. That is, it is possible to determine baseline power factor while operating the RCF equipment using such integrated meter

**Data / Parameter table 10.**

<b>Data / Parameter:</b>	$H_n$
Data unit:	hour
Description:	Operating hours of project activity unit $n$ in the project scenario
Source of data:	Measured by the project participant
Measurement procedures (if any):	Recorded continuously, aggregated monthly
Monitoring frequency:	N/A
QA/QC procedures:	N/A
Any comment:	N/A

## Appendix 1. Guidance on determination of TD losses using power flow simulation software packages

### 1. Introduction

1. The transmission & distribution technical losses (technical TD losses) are caused by physical effects of power transmission from generators to consumers through the transmission and distribution networks. Technical TD losses together with non-technical losses (e.g. caused by inaccuracy of metering) build the total TD losses which necessitate the increase of power generation for the supply of consumers.
2. Technical losses contain load-dependent (current-dependent, e.g. heating of conductors) and load-independent (voltage-dependent, e.g. losses in transformer cores) active power losses (MW).
3. RCF interventions affect mainly load-dependent losses due to the reduction of network current needed for the supplying of loads. The influence of RCF on load-independent losses is much smaller because the changes of voltages at network nodes caused by the reduction of the network current can be considered as negligible in many practical cases. Because of it the load-independent losses can be considered as fixed and unaltered independently on reactive power interventions.

### 2. Determination of average transmission and/or distribution losses using power flow simulation software

4. The use of power flow (load flow) simulation software can be used to estimate average transmission and/or distribution losses without the installation of additional measurement equipment in real networks. The base information for the simulation is the characteristics of power consumption for the loads in the network under consideration.
5. In advanced EHV and in HV electrical networks the power consumption is usually measured permanent for each feeder at the substation busbars. It means that power consumption characteristics of the loads in transmission networks are usually known and can be used for the determination of transmission and/or distribution losses in the whole network. Average values of active and reactive power consumed by the load over measuring interval can be directly determined:

$$P = \sum_n \left( \frac{P_i}{n} \right); Q = \sum_n \left( \frac{Q_i}{n} \right) \quad \text{Equation (1)}$$

Where:

- $P_i$  = Active power values, usually 15-min average values, recorded at the time point  $i$ ,  $n$  – total number of the measurement values over the observation time (e.g. 1 year), in kW
- $Q_i$  = reactive power values (usually 15-min average values) recorded at the time point  $i$ ,  $n$  – total number of the measurement values over the observation time (e.g. 1 year), in kVAr



6. In distribution networks in many cases only the values of the energy consumed by the load over the measuring time are recorded. It means that the average values of active and reactive power consumed by the load over measuring interval can be determined only indirectly as the relation of corresponded energy consumption to the duration of the observation interval (e.g. 1 year):

$$P = \frac{WP}{8760h}; Q = \frac{WQ}{8760h} \quad \text{Equation (2)}$$

Where:

- $WP$  = Annual active energy consumption  
 $WQ$  = WQ is the annual reactive energy consumption of the load under consideration determined over 8760 hours (1-year estimation period)

7. If the information about the network structure and electrical parameter of network elements (lines, transformers, etc.) is available, the whole network can be reproduced as the simulation software model and the average transmission and/or distribution losses in the whole network and/or in transmission or distribution network parts only can be directly determined from the simulation results based of the average values of the loads in the network. The practical use of simulation software packages is described in detail in Appendix 2 of this methodology.

## **Appendix 2. Guidance on use of simulation software for determining technical loss reductions**

### **1. Introduction**

1. The difference between the total electrical energy produced by power generators and the total electrical energy supplied to end-use consumers is the total electrical energy losses. The total electrical energy losses cover non-technical losses (e.g. caused by inaccuracy of metering, pilferage, etc.) and technical losses (caused by physical effects of power transmission – heating of conductors, losses in transformer cores, etc.). Technical losses contain load-dependent (current-dependent, e.g. heating of conductors) and load-independent (voltage-dependent, e.g. losses in transformer cores) active power losses (MW).
2. The total technical losses in the network is the arithmetic sum of the technical losses in all network elements (transmission lines, transformers, etc.). The total technical losses in each network element are contingent to power flows (both active and reactive power) supplying the loads working simultaneously in the whole network. To accurately calculate the technical losses in the baseline and in the project scenario in a network element, the superposition of all currents and voltages in the whole network must be simultaneously considered from the point of supply to the point of receipt. Such calculations require complex algorithms and practically cannot be done manually in many cases. The use of specialized software for the load flow simulations is recommended as an option for the evaluation of technical loss reduction due to RCF at demand side.

### **2. Scope**

3. The use of power flow (load flow) simulation software is oriented towards the calculation of the load-dependent technical losses.
4. The energy saving effect due to RCF is only attributable to its impact on load-dependent technical losses. These losses are determined using load flow simulation technique as the difference between the total losses with and without the presence of RCF under consideration.
5. Since the RCF does not have any impact on load-independent technical losses, the guidance provided below is associated only with load-dependent technical losses (technical losses hereinafter).

### **3. Criteria for the selection of simulation software**

6. The simulation software for performing the power flow (load flow) study must be in compliance with accepted International and national standards in electrical power transmission industry (e.g. IEEE Std. 399) and follow any of the following algorithms:
  - (a) Newton-Raphson method;
  - (b) Gauss-Seidel method;

- (c) Other methods providing the compliance with standard requirements for the power flow (load flow) study.

7. The above requirement shall be confirmed by a third party chartered engineer.

#### **4. Functional Characteristics**

8. The functional characteristics of the software package should include:

- (a) Load flow calculations should be able to handle meshed and/or radial networks of different rated voltages in dependence on the topology of the power system under study;
- (b) Required number of in-feeders, generators, networks nodes and loads should be supported;
- (c) Load flow calculations should consider tap changer positions of transformers;
- (d) Main types of network elements (overhead transmission lines, cables, power transformers) can be considered by the load flow calculations;
- (e) The load flow software package should support different load types;
- (f) Voltage dependences of power consumption can be considered for loads.

#### **5. Key input parameters for the software package**

9. The key input parameters should include (Refer to Section 7 of this doc for detail guidance):

- (a) Rated voltages at network nodes (kV);
- (b) Operating voltages at in-feeders and generators connection nodes (kV);
- (c) Operating system frequency (Hz);
- (d) Network topology;
- (e) Electrical parameters of main network elements:
  - (i) Resistances (Ohm/km), inductances (H/km), capacitances (F/km) and lengths (km) of transmission lines;
  - (ii) Resistances (Ohm), inductances (H), no-load losses (kVA) and tap changer positions of power transformers;
  - (iii) Electrical characteristics of loads;
  - (iv) Active power consumption P of the load under consideration (kW);
  - (v) Reactive power consumption Q of the load under consideration (kvar) or power factor of the load;
  - (vi) Voltage dependences of the power consumption P(U) and Q(U) (optionally).

## 6. Loss reduction/Energy saving estimation algorithm using simulation software

10. The baseline scenario shall be simulated by a balanced load flow study of the entire network. The balanced load flow study is an effective tool for calculating operating conditions in electrical power networks. This calculation method determines the power flow from the point of supply to the point of receipt. Conservative assumptions shall be taken into account while carrying out simulation and shall be transparently documented for the purpose of validation by the third party.
11. Loss reduction or energy saving effect of RCF is estimated using load flow analysis following the steps below:
  - (a) Identify the topology of the relevant electrical network to carry out simulation;
  - (b) List the parameters required for the simulation model according to the electrical parameters of network elements and operating characteristics of the network (voltages and frequency).
12. Determine the loads at network nodes according to electrical characteristics of load power consumption in the operating state without RCF:
  - (a) The simplest way for the load representation in the simulation model is the consideration of all loads as the consumers with constant active and reactive power consumption:  $P = \text{const}$ ,  $Q = \text{const}$ ;
  - (b) The values  $P$  (kW) and  $Q$  (kvar) can be simplified calculated as corresponding average values of power consumption from the measured or designed annual active and reactive energy consumption  $WP$  (kWh) and  $WQ$  (kvarh) as follows:
    - (i)  $P = WP / 8760\text{h}$ ;  $Q = WQ / 8760\text{h}$   
where  $WP$  is the annual active energy consumption and  $WQ$  is the annual reactive energy consumption of the load under consideration determined over 8760 hours (1-year estimation period);
  - (c) If the simulation is carried out only for transmission system, the connection points of the transmission system feeders supplying the downstream distribution systems must be considered as equivalent loads;
  - (d) The parametrization of these loads in the simulation software must be carried out using available measured values of power consumption in the feeders using the method described above for the determination of average values of load consumption;
  - (e) Location of measuring devices for the determination of equivalent load parameters in dependence on the simulation case (whole T&D network simulation or only transmission network simulation) is shown in Figure 1.
13. Carry out the load flow simulation using the input data parameter described above.
14. Calibrate the simulation results taking into account the values of the calculated voltages at each network nodes. The simulated values must be within the permissible range in accordance with power quality requirements of the utility. In case of the violence of the

permissible voltage limits ( $\pm 10\%$  deviation from the rated voltage unless and otherwise due justification is provided if other value is used) the positions of transformer tap changers and/or voltage values at the in-feeders and generator nodes must be corrected in the model parameters and the simulation must be repeated.

15. Note: The load in real networks have different electricity consumption profiles over time and therefore the maximal, minimal and average values of load power consumption are achieved by different loads not at the same point in time. The representation of the loads in simulations as consumers with constant power consumption is an important step towards the simplification and standardization of the power losses analysis using power flow simulation software.
16. If the calculated voltage values are within the permissible range in all network nodes the simulation model is considered as calibrated and the simulation results can be used for determination the total technical losses.
17. Determine the total technical active power losses in the baseline ( $P_{Losses,BL}$  (MW)) in the whole network. If the software does not provide t the total technical active power losses, it can be determined as the difference between the total active power consumed by all simulated loads and the total input active power in all in-feeders and generators nodes.
18. The annual active energy losses in the baseline scenario i.e. without RCF is estimated as follows:  $W_{Losses} = P_{Losses,BL} * 8760h$  [MWh].
19. The project scenario shall be simulated by the same processes as carried out for the baseline by repeating the calibrated simulation model established above to determine the annual active energy losses ( $P_{Losses,PJ}$ ) with RCF intervention. In other words, change the load parameters Q from  $Q_{old}$  (reactive power consumption without RCF devices) to  $Q_{new}$  (reactive power consumption with RCF). The parameters P remain unaltered. It is recommended to locate the RCF nearest to the loads with lowest values of Cos Phi, e.g. 0.8 or lower. In these cases, the effect of power losses reduction will be highest. In case of the only transmission system simulation the values of  $Q_{new}$  are determined and considered for the HV substation feeders supplying the distribution systems as the input values for corresponding equivalent loads.
20. If the calculated voltage values at network nodes violate the permissible voltage limits the necessary corrections in the model parameter as it is noted in paragraph 14 above shall be done and the simulations must be repeated. If the calculated voltage values are within the permissible limit in all network nodes, the simulation model can be used for determination of the technical losses with RCF.
21. The determination of the total technical losses  $P_{Losses,PJ}$  in the whole network after the installation of the RCF according to simulation results. Here can be used the same way of the active power losses determination as it was described in paragraph 17 above.
22. The annual active energy losses after the RCF interventions can be simplified estimated as follows:

$$W_{Losses,new} = P_{Losses,PJ} \times 8760h \text{ [MWh]} \quad \text{Equation (1)}$$

23. The calculation of the difference  $\Delta P_{Losses}$  (MW) between the total technical active power losses values determined for the load operating state without RCF and for the load

operating state with RCF. This difference characterizes the reduction of total active power generation in the network due to the use of RCF and therefore the reduction of total technical active power losses after the RCF interventions.

24. The estimation of the annual loss reduction/energy saving effect  $\Delta W_{Losses}$  caused by the RCF interventions can be simplified calculated as follows:

$$\Delta W_{Losses} = \Delta P_{Losses} \times 8760h [MWh] \quad \text{Equation (2)}$$

25. For the purpose of estimating loss reduction/energy savings during each year of the monitoring period, the project participant shall carry out the calibrated simulation exercises as described above in each monitoring period after the implementation of RCF using the actual network data to determine technical losses both in the baseline and in the project scenario. The ex-post simulation also shall determine baseline technical losses that would have occurred in the baseline scenario had it been operated without RCF (i.e. simulation using baseline power factor). The baseline technical losses are then simulated that occur during the transmission phase.
26. The simulation results shall be confirmed by third party chartered engineer. Since the software is standardized, the simulation need not be performed by any third party, it can be either carried out by the technology supplier or by the project participant themselves. But the operation of the simulation software should be explained to the third party and the actual software shall be shared during validation. The third party shall verify that the software used by the project participant is in compliance with International Standards or equivalent in power transmission technology and as per standard industry practices.

## 7. Guidance on parameters required to determine technical loss reduction using simulation software

27. The parameters listed below allow for the calculation of losses that occur at the various stages of a power transmission/distribution system, i.e. substation and transmission/distribution line. The station losses and transmission/distribution line losses together represent the technical losses (only load/current dependent) that occur during the transmission/distribution of power flow (with/without RCF), i.e. fixed losses (e.g. core losses in transformer) and reactive power losses in transmission lines are not considered for this methodology.
28. The station losses comprise the following two types of losses:
- (a) Transformer losses (two components):
    - (i) Winding loss. The winding loss is a result of the resistance of the windings and is proportional to the square of the current through the transformer;
    - (ii) Core losses;
  - (b) The transmission line losses comprise the following losses:
    - (i) Ohmic losses: The passage of current through the conductors (of a transmission line) results in power losses due to resistance of the conductors. This loss is referred to as the ohmic losses;

29. The simulation software as described in Appendix 1 shall be chosen in order that the following parameters are used to compute station losses and transmission/distribution line losses:
- (a) **Rated power transformer voltage.** The voltage assigned to be applied, or developed at no-load, between the terminals of an untapped winding, or of a tapped winding connected on the principal tapping. For a three-phase winding it is the voltage between line terminals. This parameter is the key design parameter of a transformer, which in addition to the kVA rating is used to calculate the rated current of the transformer, and therefore, the losses that would occur during the course of operation of the equipment;
  - (b) **Rated power transformer kVA.** The kVA rating of a transformer is the apparent power handling capability of the transformer. This is a conventional value of apparent power assigned to a winding which, together with the rated voltage of the winding, determines its rated current, which affects the losses that occur in the transformer during course of operation;
  - (c) **Power transformer ratio.** The power transformer ratio is the ratio of the number of turns in primary winding and secondary winding. This is same as the ratio of primary voltage and secondary voltage;
  - (d) **Percent impedance.** Short-circuit impedance of a pair of windings is the percentage ratio of "voltage applied to primary winding to maintain rated current in the short circuited secondary winding" and the rated voltage of primary winding;
  - (e) **Relevance of parameters under points a, b, c and d above.** All these design parameters are the characteristics of a transformer, and transformer no-load and load losses are dependent upon these design parameters. The transformer copper losses comprise the total losses that take place in the transformer connected at the sub-station. Further, the transformer losses comprise the bulk of the losses that occur in a substation. The parameters listed above are required to compute the transformer losses at any point the transmission/distribution line is in operation;
  - (f) **Full load copper test loss (Watts).** These are the power losses which occur due to the flow of current in the copper winding and are proportional of the square of the current;
  - (g) **Relevance.** These losses vary with respect to the loading on the transformer, and have a direct bearing on the terminal station losses;
  - (h) **Resistance and reactance per unit length.** The resistance of the transmission line is the ohmic resistance of the line per unit of line length. This is evaluated after considering the proximity and skin effect. This is responsible for the power losses in the line and voltage drop across the line. The resistance is inversely proportional to the area of the conductor and directly proportional to the resistance of the conductor;
  - (i) The reactance of the line in combination with the resistance, contributes to the voltage drop across the transmission line;
  - (j) **Relevance.** Ohmic losses are directly proportional to the resistance of the power transmission line. This forms a major part of the transmission losses. Reactance

AMS-II.T.

Small-scale Methodology: Emission reduction through reactive power compensation in power distribution network

Version 02.0

Sectoral scope(s): 02

---

contributes to voltage drop in the transmission line and is only indirectly related to the loss calculation.



**Figure 1. Location of measuring devices for load consumption analysis in TD network**

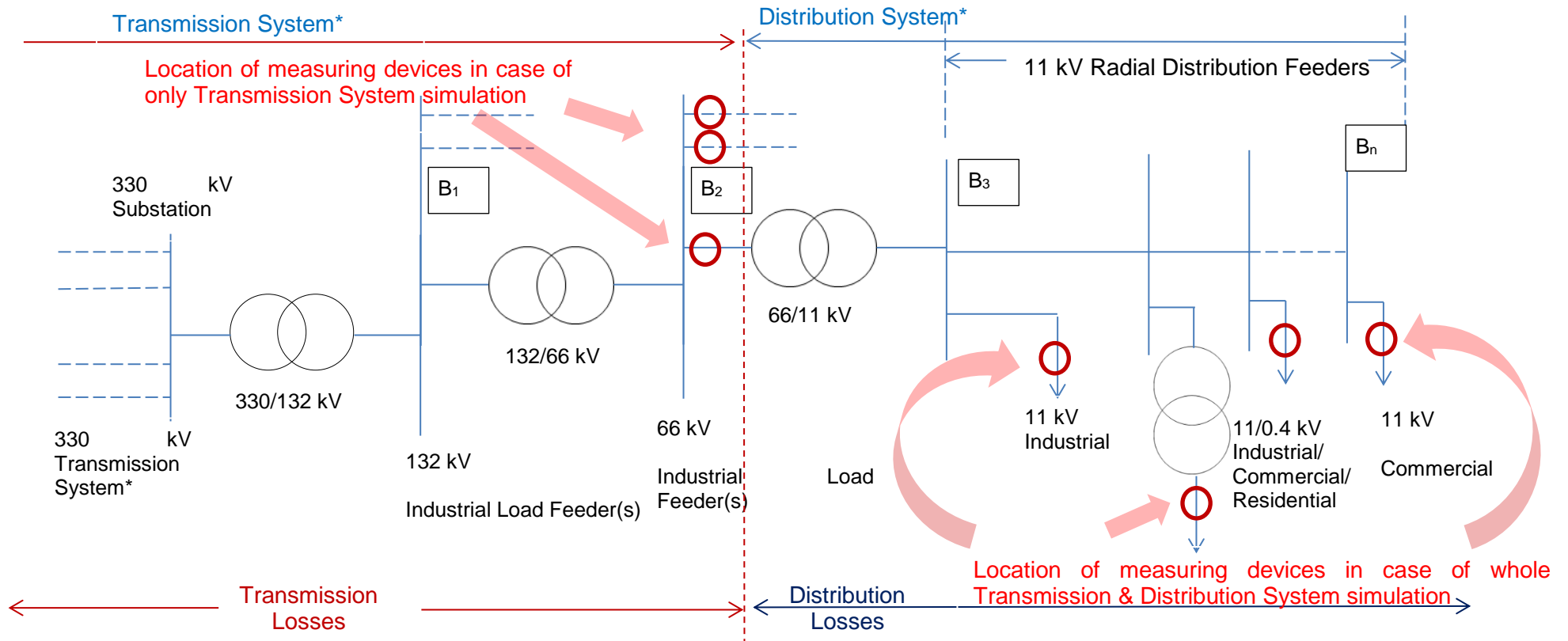

Note: The representation of transmission and distribution systems is country-dependent. In some countries 132 kV and 66 kV networks belong to transmission systems.

## Appendix 3. Procedure to estimate transformer copper loss reductions

1. The transformer losses consist of iron losses and Copper losses. Iron losses are no-load losses and are independent of current. The copper losses vary with the square of the current and depend on power factor. Thus, for the purpose of estimating loss reduction/energy savings through power factor improvement, iron loss component is excluded.
2. This loss reduction associated with transformer copper losses may be included in addition to T and/or D loss reduction at upstream due to RCF intervention. The procedure contained in this document is limited to transformer Cu loss reduction estimation for industrial customers where utility metering is located at HV side and RCF is at LV side of transformers, and required data on transformers (kVA rating and CU losses) are also available.
3. The figure 1 below illustrates a setup, where transformer losses may be considered, following the guidance of paragraph 28 of Appendix 2.
4. Transformer copper losses with baseline power factor are calculated as follows:

$$T_{loss,BL,y} = P_{cu} \times \left( \frac{P_{demand,y}}{S \times \cos \alpha_{H,n}} \right)^2 \quad \text{Equation (1)}$$

5. Transformer copper losses with project power factor are determined as follows:

$$T_{loss,PJ,y} = P_{cu} \times \left( \frac{P_{demand,y}}{S \times \cos \beta_{H,n}} \right)^2 \quad \text{Equation (2)}$$

Where:

$S$	=	rated kVA of transformer
$P_{demand}$	=	actual loading in kW
$P_{cu}$	=	Copper loss as determined from the manufacturer's specification or name plate of the facility transformers or from the standard engineering handbook. In the case values are reported in the ranges, minimum shall be used for conservativeness.

6. The baseline and project transformer copper energy losses can be calculated as follows:

$$W_{Culoss,BL,y} = T_{loss,BL,y} \times 8760 \quad \text{Equation (3)}$$

$$W_{Culoss,PJ,y} = T_{loss,PJ,y} \times 8760 \quad \text{Equation (4)}$$

Where:

$W_{Culoss,BL,y}$  = transformer copper energy losses with baseline power factor

$W_{Culoss,PJ,y}$  = transformer copper energy losses with project power factor

**Figure 1. Consideration of Transformer Losses**

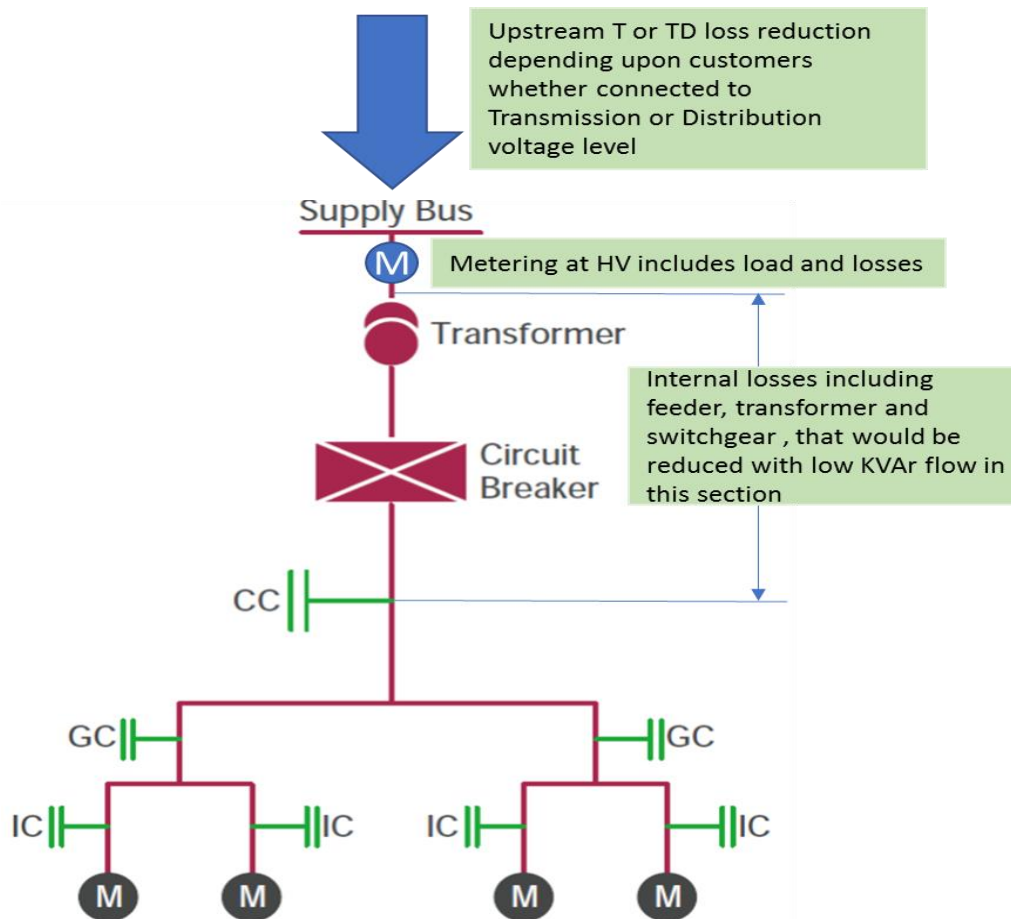

**Box 1. Example – Consideration of Transformer Copper Losses**

$S = 500 \text{ kVA}$   
 $P_{demand,y} = 300 \text{ kW (Average)}$   
 $\text{Cos}\phi_{BL} = 0.8$   
 $P_{cu} = 4600 \text{ W (assumed for a 500 kVA Transformer)}$   
 $T_{loss,BL,y} = 2588 \text{ W (from eqn (1))}$

**If power factor is improved to e.g. 0.99**

$T_{loss,PJ,y} = 1623 \text{ W (from eqn (2))}$   
 $\% \text{ CU loss reduction } (2588 - 1623) / 2588 = 34\%$

-----

### Document information

---

<i>Version</i>	<i>Date</i>	<i>Description</i>
02.0	28 March 2019	EB 102, Annex 10 Revision to: <ul style="list-style-type: none"><li>• Include an additional option to calculate emission reductions using a simulation modelling approach;</li><li>• Include copper losses of facility transformers under option 2.</li></ul>
01.0	4 May 2017	EB 94, Annex 8 Initial adoption.

---

Decision Class: Regulatory  
Document Type: Standard  
Business Function: Methodology  
Keywords: electric power transmission, simplified methodologies, type (ii) projects

---